

**NYLON
HIGHWAY
#43**

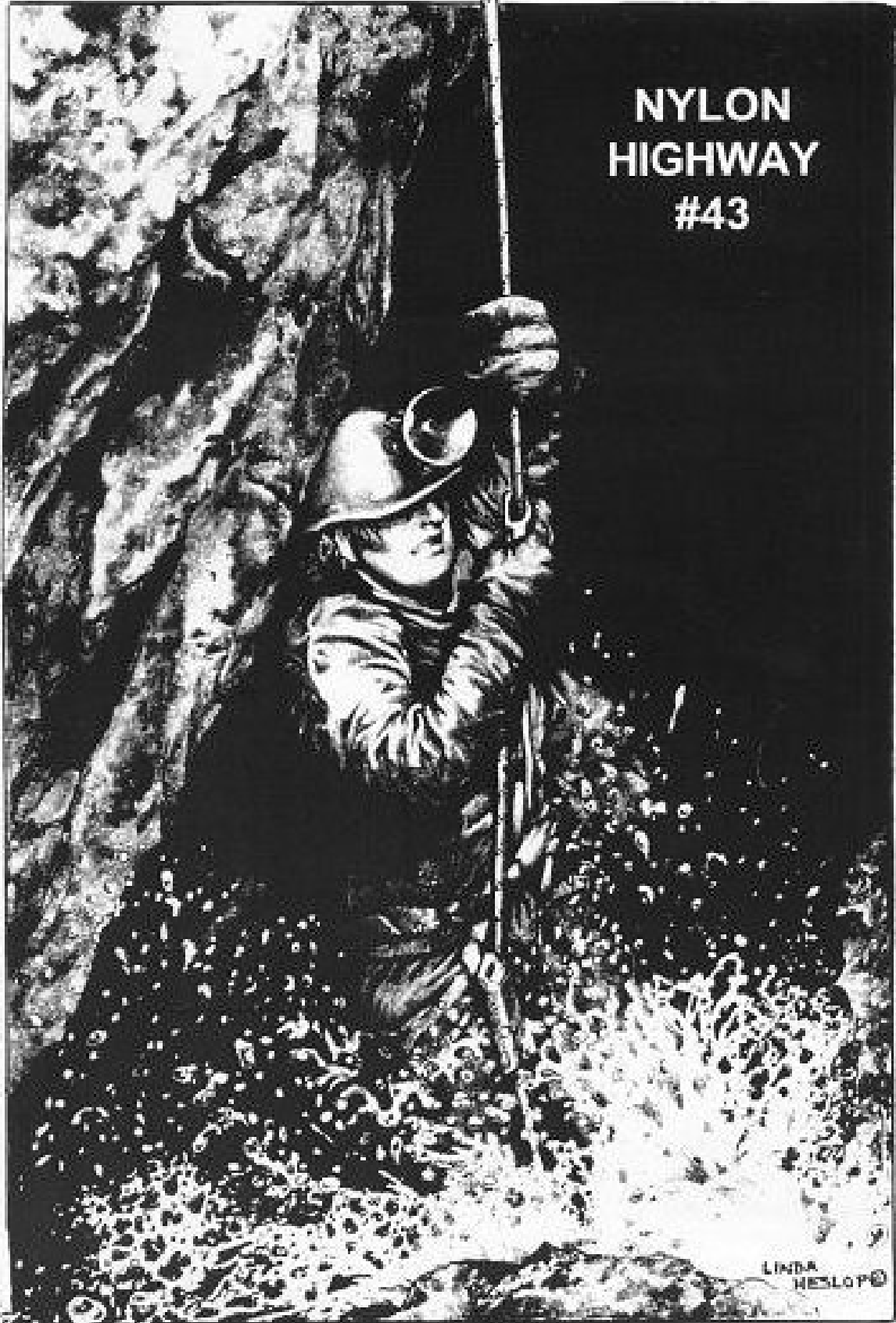

LINDA
HESLOP®



#43

Contents

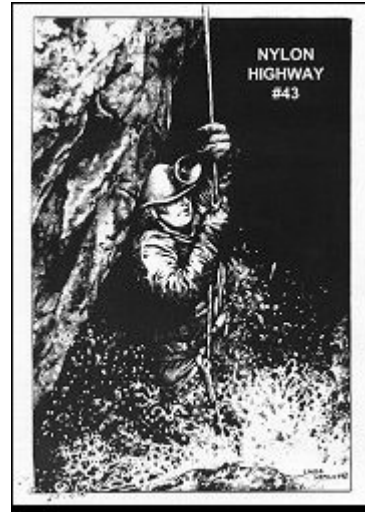

Overleaf

NH #43

1. **Message From The Editor, by Wm Shrewsbury**
2. **Secrets I Was Never Told, by Bruce Smith**
3. **Notes From The Internet #1 - Left-Handed Racks, by Wm Shrewsbury**
4. **Rigging A European Pit, translated by Peter Grant**
5. **Tying The Münter Hitch, by Lee Trowbridge**
6. **Rope Centering On A Narrow Rack, by Ron Simmons**
7. **Safety & Rescue: There Are Limits, by Bruce Smith**
8. **How Well Do You Know Your Knots?, by Bruce Smith**
9. **Making The Most Of Climbing Practice, by Kevin Harris**
10. **How-To Books Worth Reading, by Bill Mixon**
11. **Reminders For Safe Caving, by Miriam Cuddington**
12. **Minutes Of The 1996 VS Meeting, by Bill Bussey**

Advertisements

Copyright © 2000 Vertical Section of the NSS, Inc.
All Rights Reserved.

Nylon Highway

Bill Bussey..... Chairman
3007 Mt. Mariah Road
Durham, NC 27707-9023
e-mail: billbus@gte.net

David Joaquim..... Secretary/Treasurer
8120 E. Mitchell Dr.
Scottsdale, AZ 85251-5812
e-mail: nssvertical@pcslink.com

Wm Shrewsbury..... Editor
(423) 886-3296
PO Box 4444
Chattanooga, TN 37405-0444
e-mail: taglite@bigfoot.com

Bruce Smith..... Education Coordinator
6313 Jan Lane Drive
Harrison, TN 37341-9419
e-mail: onrope1@bigfoot.com

Bill Cuddington
..... Vertical Contest Chairman
3412 Hutchens Avenue
Huntsville, AL 35801
e-mail: miriambl@aol.com

Allen Padgett
..... Vertical Techniques Workshop Coordinator
920 Cordell Avenue
LaFayette, GA 30728-2843
e-mail: 75313.25@compuserve.com

Please send articles, art, exchange publications
and other material for publication in the Nylon
Highway to:

Wm Shrewsbury
PO Box 4444
Chattanooga, TN 37405-0444
e-mail: taglite@bigfoot.com

ISSN 1071-2615

March 1999
ISSUE #43

The Nylon Highway is published by the Vertical Section of the National Speleological Society on a semi-annual basis pending sufficient material. It is the intent of this publication to provide a vehicle for papers on vertical work. All submitted articles containing unsafe practices will be returned to the author.

Opinions expressed herein are credited to the author and do not necessarily agree with those of the Vertical Section, its members or its Executive Committee.

All materials are copyrighted by the Vertical Section and require written permission before reprinting. Reprinted material must credit the original author and the source.

Please send payment for ads, subscriptions, renewals, request for back issues, address changes and all correspondence that doesn't have to do with anything you'll ever want published to:

David Joaquim
8120 E. Mitchell Dr.
Scottsdale, AZ 85251-5812
e-mail: nssvertical@pcslink.com

In short, if you'd like to submit something for possible publication, send it to the Editor. Otherwise, send it to the Secretary/Treasurer.

See our new web page at: <http://www.caves.org/section/vertical>

Copyright © 2000 Vertical Section of the NSS, Inc. - All Rights Reserved.

Message from the Editor

Wm Shrewsbury, NSS #22677RL FE (Chattanooga, TN)

In this issue we have an assortment of articles from some well known (or soon to be well known) people. Bruce Smith leads off by telling us all of his 'Secrets I Was Never Told'. This is followed by a short answer to a question that was asked of the editor over the internet. Ever wonder how they rig in France? Read a translation by Peter Grant.

Purchased a narrow rack and can't get the rope to run right? Ron Simmons sets it straight. Kevin Harris's article will help you make the most of your climbing practice. Miriam Cuddington reminds us how to be a safe caver. Need some new reading material? Bill Mixon gives us a few how-to book titles on SRT. Of course, there are the minutes of the 1996 Vertical Section Meeting. Safety and Rescue - two words used a little too often. Bruce Smith gives us the 'Peter Piper' of all statements.

Finally, how well do you know your knots? Take the test inside and see how well you do!

If you have an article or photo that you think we could use, send it to us. I know there are some cavers out there working on new gear. What better way to introduce it than through the Nylon Highway? Send your articles and photos. We can read most formats. Reasonable handwriting is gladly accepted. E-mail submissions are even better.

Stay tuned for the next exciting issue featuring articles by YOU! I for one can't wait to read about them

Cave Softly and Carry a Long Rope,

Wm Shrewsbury, Editor

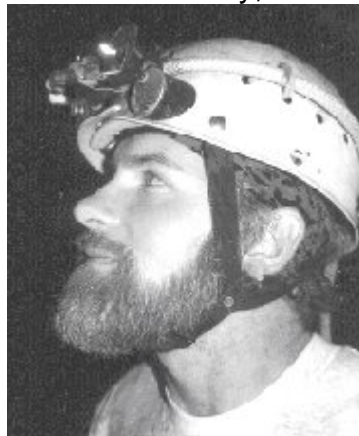

Secrets I Was Never Told

By Bruce W. Smith

Ascending and negotiating long drops has always been one of the most thrilling parts of vertical work I can remember. Unfortunately, the pain of the ascent has always challenged my endurance. 39 years later, I've put together a list of techniques that limits the pain to a point of almost painless.

Painless Climbing!?!? "Tell me more!"

It was early March '98, I was in the shadow of my 50th birthday, 40 pounds overweight, out of shape and had planned to enjoy an entrance visit to Sotono de Las Golondrinas (1090' on the low side) the longest subterranean free fall drop in the world

A group from the Czech Republic and a large hive of bees had taken up residency along the entire lip of the low side. The seven of us moved up and around to the right to a prominent tree that was dwarfed by a non-descript jungle around it This additional elevation convinced me that I would never see the bottom of this pit.

Polyester became our highway and one by one each one of us put on our gear and disappeared into the darkness. "Your turn," was directed to me and like I had planned to descend all along, I got on rope and enjoyed a very smooth one minute ride to the bottom.

Peer Pressure! "Oh sh--!" I said to myself, ***"What had I done?!"*** I was standing on 7 acres of guano looking up about 1150 feet listening to supersonic sparrows diving through the blackness in search of food, all the while, evading the parrots who were also searching for food-them! Occasionally, one could see a set of sparrow tail feathers sticking up out of the guano from one dive bomber who had miscalculated his dive pull-out.

I decided it was time to get real serious! What had I learned over the years that would allow me to reach the surface with some assemblage of dignity. The burrows at the bottom of the mountain were a remote option, however it would be closely associated with a loss of dignity-even disgrace!

Joe Ivy once told me the best medicine for the body was an I-V or continuous fluids. This had to be part of my plan. (1) Drink a gulp of water every time I stopped. Oxygen debt was a killer so (2) I decided never to get out of breath, that way, I would never have to catch it. Breathing restrictions all must be eliminated. (3) No belts whatsoever. No battery belts, no tight harness belts, nothing. When I sit down, it is important for waist girth to have a place to go other than up into my rib cage restricting lung capacity.

I had cloned myself a Forrest Harness (4). This harness supports its user under

the thighs and hips and the fleshy parts of the buttocks. The waist belt serves only as a back support or balance component. This waist belt can be loosened or tightened as desired without the risk of disconnecting any important life support component.

A double chest roller would prove to be an important element of the climbing system. A Double Bungie Climbing System would be my elevator to the top, but with a balloon chest and other burdens of the flesh, sitting down to rest results in an immediate "uppsy-daisy" feet up and head down. (More lost dignity points) Snapping my QAS into the right roller of the Double roller Chest harness insured up-right resting.

Resting is important, If you're going to stop and rest, let's make sure it is a restful time. With belts and other girthing components, I have found myself breathing harder, light headed, and in the early stages of suffocation.

A helmet mounted battery pack was important (6), no waist belt supporting a battery. Harness became important (7). With the threat of Compartmental syndrome, I added pads to shoulder straps, chest roller belt, leg loops and the harness waist belt.

Positioning (8): I placed myself above my tandem partner. That way, I could raise and lower the chest roller from Adams apple to Belly's button and it would work the same. Surely, my lats under my armpits would give out and ache to intolerance if I was unable to raise and lower the chest roller as one by one of my back muscles gave up to the pain.

Technique (9): This was, by far, the biggest part of the equation. Putting all this into action into some sort of fluid non-embarrassing sequence was the challenge. But there was another significant technique that I'd only lately thought about and decide to materialize my concept into reality.

Everyone should climb with a rhythm or so we've always been told, but this time I let my muscles establish the rhythm. Just before the leg muscle burn, I determined I'd stop-remain standing for 5 to 10 seconds to let the toxic acidic, used-up blood leave my legs and find it's way to the bleeding cleaning and refueling substations, i.e., kidneys, Lungs, spleen, and the liver and then I would sit down.

Levitation (10) Didn't I mention this yet? I was told in the end, I really wouldn't have to worry about 1 thru 9 because the majesty and grandeur of the pit would lift me through the blackness in some magical way.

**No Cramps, No Aches,
No muscle burn, No exhaustion.**

Sooner or later the inevitable came to pass. I was on rope. I took three steps. "So much for number 10. Levitation was not working!" I was facing hard work.

I climbed 30 cycles **and sat down** to rest while Becky attached below me. Bad move! My legs burned. I stood up. They hurt worse than when I sat down. Number 9 says wait 5 to 10 seconds. So I tried again. 30 steps-stand for 5 to 10 seconds, sit, gulp water, climb 30 cycles, stop-stand 5 to 10 seconds, then sit, gulp water, repeat, repeat. **It was working.** The legs stayed fresh and hard, Never loose your breath! Stop, but don't just plop down into your harness. Stay standing for 5 to 10 seconds, then sit down.

**This is really working!
Set goals, keep a pace, keep a rhythm.
Count your cycles as you climb.
Stop and stand 5 to 10 seconds
before sitting and resting.
When you sit, take a gulp of water,
wait on your partner below. Repeat.**

After 500-600 feet the chest and seat began to wear at the muscles certain muscles. So during resting periods, I loosened the chest and lowered it 2 to 3 inches. Becky's weight below me maintained my up-rightness regardless of where I placed it. Before it was done I wore my chest harness all over my torso and the next day, I had minimal muscle soreness or tenderness.

Looking across and down, I could see the Czech's low rig point in the moonlight telling me I was close. At the edge, I found I had plenty of reserve strength to negotiate the lip with confident moves. Over the lip--QAS in place--Step--Firma Terra--Ascenders off. I stood up to solid hard legs, no milky leg feeling, I experienced no cramps, no numbness, no aching, no exhaustion.

Yes, I was tired, but not embarrassingly tired. My triceps were sore from assisting my ascent with mini-pull-ups, overall, I dialed into a magic combination.

I took a Calcium tablet and Potassium tablet back at the car. I had gulped 1 1/4 quarts of water and had not dripped sweat on Becky (She especially appreciated that).

So what is the big secret?

1. Drink a gulp of water at every stop.
2. Don't get out of breath so you don't have to catch your breath.
3. No belts. No breathing restrictions.
4. A Harness that suspends from the leg loops.
5. A double chest roller maintains uprightness during resting.
6. Helmet mounted battery pack (no belts) for light.
7. Harness padding.
8. Top position during a tandem climb.
9. Technique: Wait 5-10 seconds before sitting to rest, set goals and count cycles.
10. Levitation (over rated - It doesn't work that well).

Someone will ultimately say, Everybody knows all this, well, I'm here to tell you that these are secrets that I was never told all at the same time.

Notes from the Internet

#1 - Left Handed Racks

By Wm Shrewsbury, NSS #22677 (Chattanooga, TN)

Have you ever heard of someone making a rappel rack for left handed people? So that the short end of the rack is on the left, and the rope comes off the left side, to be guided by the left hand? Can you change a regular rack around that way, without any danger?

I (the editor) just happen to rappel left handed. Here are a couple of ways to accomodate our South Pole styles.

The normal setup:

The rope runs over the top of the first bar:

To achieve this, just remove all but one bar from your rack. Turn your rack over (open leg to the left) and slide the last bar down the open leg. Immediately turn it over once it clears and put it back on. Leave it on the short leg. Now, simply add the other bars, turning them opposite to each other as you add them, using the bar left on the rack as a starting guide. When all your bars are on, move each one to the long leg of the rack, put your locknut back on the rack, and have fun!

The abnormal setup:

The rope runs under the top of the first bar:

I prefer this, since it keeps my rack away from the wall and out from under the rope on lips. Since backing over a lip is usually the toughest part, this also removes a bar (it doesn't touch the top bar) as I back up, but immediately and automatically adds it after I get over the lip. I also have a little better control with the # of bars the rope touches since this removes about 1/2 bar while rappelling (direction of rope after it leaves bottom bar). This also has the advantage that if I hand my rack to someone else, it is already setup to rappel right handed.



Rigging A European Pit, Doing it the French Way.

Translations from the French

By Peter Grant, NSS #5719 (Bristol, VT)

(From "Techniques de la Speleologie Alpine", by Marbach and Rocourt, a review. Techniques Sportives Appliquees France 38680 Churanche)

Primary considerations:

1. Protecting the rope from any rubbing points (frottements) against rock
2. Have two anchors at the top of the rope, Principal (P) and Security (S) backup,
3. The principal anchor allows the rope to go the extent of the drop without rubbing, or at least no rubbing to a deviation or fractionment.
4. Use Deviations to keep the rope from the rock, by using a sling from the opposite wall or a metal loop welded to a bolt. See illustrations.
5. Use Fractionments, tying the rope off on an anchor, fractionments are called rebelays by the British.
6. Don't just drop the end of a rope down the pit. Carry it down in a rope bag, letting it be pulled out as the rigger descends and places rebelays. That prevents tangles ropes and rocks falling on coils on the bottom.
7. Avoid rope bends, which are knots used to connect two ropes, in the middle of a drop, if possible. Start the next rope at a fractionment, tying the excess of the upper rope off in a loop below the anchor.
8. Use a slip knot (Noeud Amortisserr, NA) between the safety and principal anchor. If the principal anchor comes loose, the shock of the climbers weight hitting the safety anchor will not be as severe due to the slipping knot giving a dynamic stretch effect, to keep the rope from breaking.
9. Be careful of natural anchors (amarrages natural) like rock loose and stalactites that might break or the rope being at an angle that might slip off. Other anchors are rock climbers pitons and nuts as well as bolts. All these should be used with care and instructions for proper use should be reviewed.
10. Use a second security anchor if the first one is far from the principal anchor, also the climber doesn't swing too far if the principal breaks.
11. If two principal anchors are used at either side of a drop, to get the rope to hang in the middle, far from each wall, make sure the angle at the center knot is not too near 180 degrees, that is, make sure the rope between the anchors sags a lot. An angle of 90 degrees is safest, puts less strain on the rope, than 120 degrees and getting near a straight line, or 180 degrees, can easily break the rope with a small weight below.
12. Keep track of where the rope would go if the principal anchor breaks. When the tension is caught by the security anchor, will the rope be over a

sharp edge that may cut the rope?

13. Make sure the deviations and fractionments can be crossed by standard climbing techniques. The deviations can sometimes be disconnected for crossing and then reconnected. Be careful as sometimes this may be difficult. A fractionment means moving gear from one rope to the other, so a two meter loop is needed at the bottom of the upper rope to allow this action.
 14. Make sure one of the anchors is accessible to the climber without having to get too near the edge of the drop. The climber would use a longe longue (British long cows-tail) as a safety to get to the main drop rope.
 15. If the fractionment is over 45 inches below the last anchor, use two anchors, again a principal one and one for the security.
-

Tying the Münter Hitch

By Lee Trowbridge, NSS #33443 (Oak Ridge, TN)

(Editor's Note: This article was published in *Nylon Highway* #39, but the drawings were left off. It is reprinted here for clarity.)

The Münter hitch is a useful knot which can serve as a simple, effective belay device. In a pinch, accompanied by a leg wrap, it can be used for short rappels in preference to the "biner wrap". The only hardware required is a carabiner; preferably a steel one for reasons of abrasion resistance. According to Padgett and Smith's *On Rope*, as a belay device the Münter hitch can provide more frictional force than either a figure-8 or a stitch plate.

In *On Rope*, a relatively simple technique is described to tie the Münter hitch, and with the book open in front of you, it is no trouble at all to tie this knot. In a dark muddy cave however, even the simplest task can be more difficult than is easily appreciated in the comfort of one's living room. Having once needing three tries to tie this know (no, I can't explain the mental lapse), it occurred to me that a more easily remembered means of tying it would have helped. The accompanying diagram shows such a method. It is essentially a variation of the *On Rope* method, but with the rope distorted so that it appears more symmetric. This method consists of four parts:

1. Form a bight on the main rope,
2. Twist the bight a full 360 degrees,
3. Clip the carabiner above and below the twist,
4. Anchor the carabiner and pull on the load end of the rope.

The carabiner of course needs to be anchored appropriately (to what, depends on the intended use.) The Münter hitch is self-reversing. That is, either end can support the load, the other being the belayer's end.

Should the load reverse, the knot will flip to the other end of the carabiner and reverse. This technique has made it easier for me to remember how to tie this useful knot (even under duress), and hopefully it will prove useful to others.

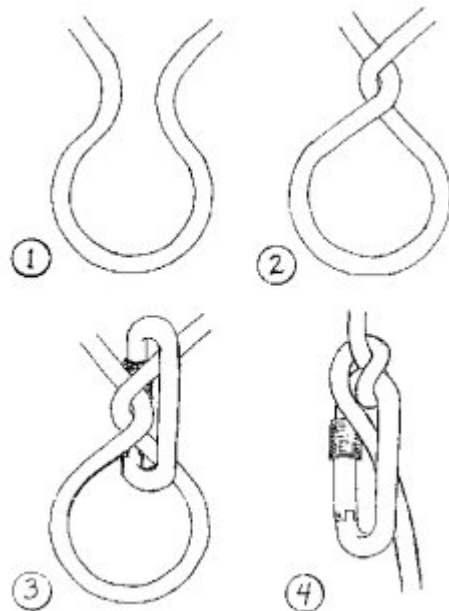

Reprinted from *Nylon Highway* #39. Previously printed in the *D.C. Speleograph* - August 1994, Originally printed in the *Speleotype*, January 1994 - East TN Grotto.

Rope Centering on a Narrow Rack

By Ron Simmons, NSS #16894 (Charlottesville, VA)

I have been using one of Larry Howell's Titanium racks for some time now. The one I use is the five bar rack with the narrow frame. I love the rack and use it everywhere but needed to find a way to center the rope in the rack. Below I describe the method that I came up with.

Without any kind of guide the rope will slide off toward the eye side of the rack. I did not want to put a starter groove in my top bar or go to a larger top bar. So what I did was to let the spacers between the top two bars do the guiding, see fig. 2.

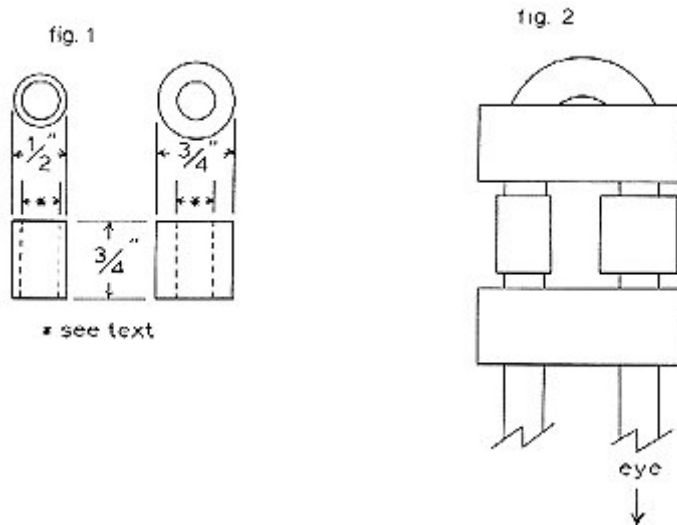

To keep the rope centered the spacer on the eye side of the rack frame needs to push the rope back toward the center. After trying several different sizes the one that I found to work best are shown in figure #1. The spacers are drilled out with a W drill (.386"). The spacer on the eye side of the frame is 3/4" in diameter and the other one is 1/2" in diameter. I made them of Delrin plastic but other materials can also be used except nylon. You do not want a nylon rope running over a nylon spacer. The Delrin is light and wears well. Small groves are worn into the larger spacer but it rotates enough to spread the wear out. I have over 2000' on my set.

This extra effort to center the rope may seem a bit picky but I think that it improves the handling of the rack. Also with a narrow rack frame the rope will wear groves into the frame if the rope is not centered.

"Safety" and "Rescue": There are Limits

By Bruce Smith, NSS #12458, (Harrison, TN)

As we have evolved, I have grown more sensitive to the use of terms, their meanings, accuracy, appropriateness, and correctness. Two words that cropped up and are being used inappropriately and do not accurately describe or identify items or situations. These two words are *safety* and *rescue*. More and more I hear conversations that follow something like this:

"When I arrived on the *rescue* scene in my *rescue* vehicle, I turned off the engine and set the *safety* brake. Grabbing my *rescue* gear, I moved over toward *rescue* command and was given directions to join the *rescue* team entering the cave. When I got to the cave, I put on my *rescue* harness, making sure I had all my *rescue* and *safety* equipment, and yelled, "On rope". I checked out the rigging and noticed a *safety* back-up with a double *safety* lanyard along with a *safety* line for the difficult lip. There was also another *safety* belay line which appeared to be *rescue* Super Blue. I clipped my *safety* to the *rescue* orange *safety* rope and attached my *Rescue* 8. I check myself out, had one of my *rescue* buddies check me out, unclipped my *safety* and shouted, "On rappel"...."

In almost every case in the above contrived dialogue the words *safety* and *rescue* could have been eliminated or items called by their correct names. Correct names are often more descriptive and leave very little to misunderstanding. Even though these two words started out years ago, primarily as nouns, there are places and time when they are appropriate as adjectives. I find them most offensive when used as adverbs. I think some of the improper use comes from equipment manufacturers that attempt to type their products or make them sound better or more interesting than they are.

My concern is that when the real need for the word *safety* and *rescue* are needed they will not have the impact they need due to their meanings having been so diluted in our everyday speech. Surely, we can find better words or adjectives to describe the gear and situation that we encounter without overusing these two words.

How Well Do You Know Your Knots?

By Bruce Smith, NSS #12458, (Harrison, TN)

It became apparent to me last winter during a rescue when it was necessary to tie approximately 50 Running Bowlines in the dark while climbing an ice covered tree during a driving rain and ice storm. Reaching over my head, I carefully tied each one as the ice and rain pounded into my eyes, freezing as it hit my face. The viewing angle of the knot was strange as I was looking at the end of the knot and often the knot was oriented on the back side of the tree and I couldn't even see it.

Slowly, for two hours, I worked up the tree in the howling storm, knowing full well that if I made one mistake with just one knot, I would have tumbled over 80 feet, snapping off ice coated limbs before my own personal rendezvous with the emergency room. All this, for a cat. Putting my poor judgement aside, I got to thinking about how well I had to know my knots during this rescue episode. So here's a little test. Oh, by the way, the cat made it.

Can you identify these ten knots from viewpoints that we're not routinely exposed to? *(Type your answers in the boxes.)*

1.



2.

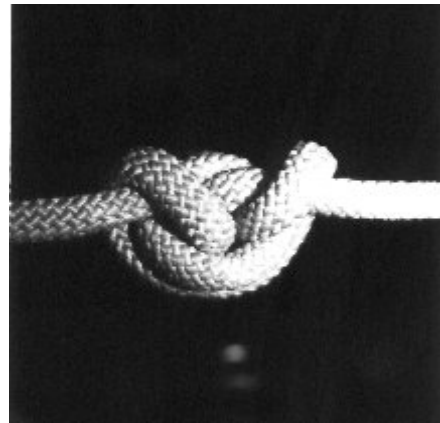

3.

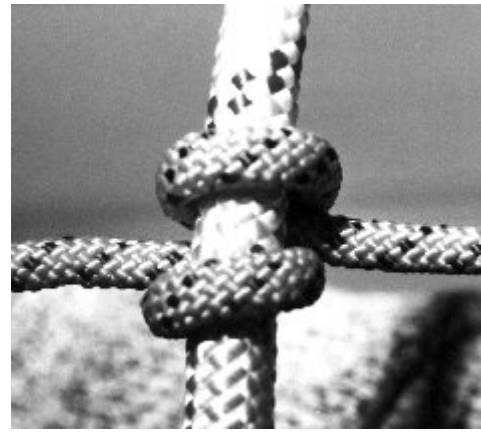

4.

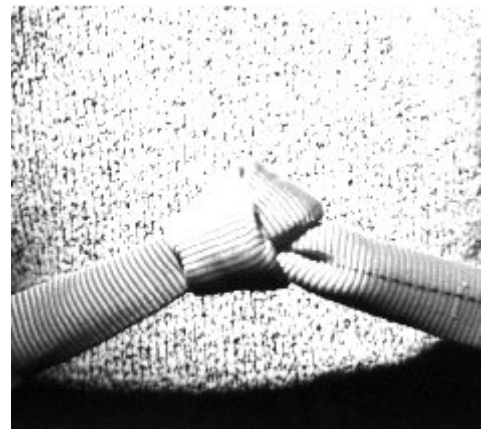

5.

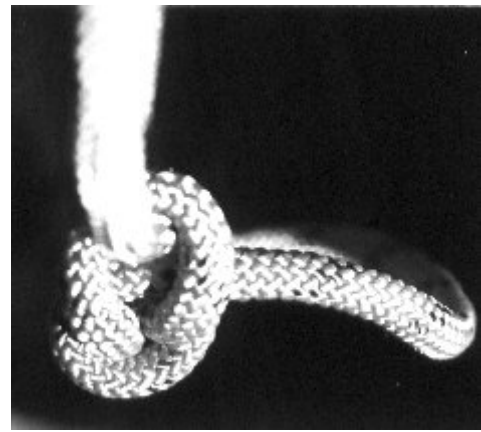

6.

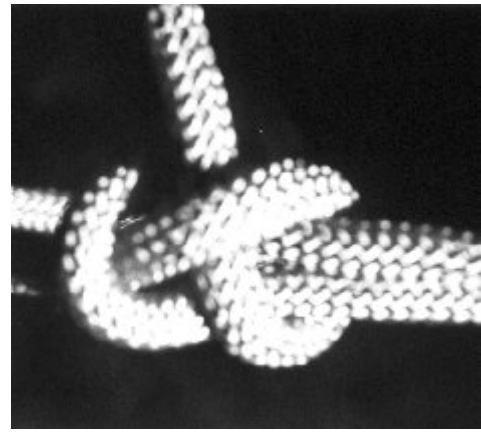

7.



8.



(Don't peek until you've filled out the answers.)

Answers to the Knot Test

No.	Correct Answer	Your Answer
1)	Running Bowline	
2)	Butterfly	
3)	Clove Hitch	
4)	Beer Knot	
5)	Bowline	
6)	Sheet Bend	
7)	Bowline with Yosemite Tie-Off	
8)	Ring Bend (Water Knot)	

How well did you do?

Correct

8

5 - 7

1 - 4

0

Rigger Status

Master Knotsman

Junior Knotsman

Knotsman Wanabe

Never Mind - I'll rig it myself!

Making the Most of Climbing Practice

By Kevin Harris, NSS #16868 (Nashua, NH)

You can get many more benefits out of climbing practice if you give it a little thought ahead of time and try something new or different. While climbing systems can be used comfortably by most healthy adults, however, equipment and techniques are not good substitutes for fitness. Plan ahead and do some running, biking or aerobics so that you won't run out of steam halfway up a rope climb. Use climbers putty to strengthen your hand so that you can work your rappel rack under the load of your body weight.

Check out your equipment ahead of the scheduled practice. You don't want to make others wait because you don't have your gear in order. If you need a piece of equipment to complete your rig, buy it or make it now. If your rope is dirty or worn, now is the time to clean or replace it. If an ascender is muddy or a carabiner is hard to open, it is time to clean and lube it. If you have trouble putting on your harness or slings, now is the time to practice, so you won't waste time fumbling when it is your turn to climb. "Tune" your rack, as discussed in *On Rope*. Adjust the fit of your harnesses to your new size or new clothes.

It is a good idea to pick up an extra length of sling or hand line; this can help you adjust your rig for comfort or flexibility. Wearing a pair of finger-less biking gloves can protect your hands and yet retain dexterity to work the equipment while hanging in space.

Before leaving for practice, be sure to pack some food and water. A bottle of cold water sure tastes good after that struggle to get over the lip after a long climb. Don't forget your helmet, boots and some sunscreen! Leave your jewelry (rings, earrings, etc.) At home, since they can cause problems. Make sure long hair is tied up so it doesn't get caught in the rappel device.

Once at the practice site, consider learning a new knot, learning how to pad the lip to see how the lip rigging affects the ease of the rappel and climb. If you never rigged the rope before, try your hand at it.

Practice adjusting the friction of your rack so that you can pass the lip comfortably in a standing position without tipping to far back or forward. Once past the lip, practice adjusting the friction on the way down to speed up and slow down. Alternate between fast and slow just by sliding the bottom bar up and down an inch or so.

Practice stopping, tying off and adding and removing bars on your rack while moving. All of these skills are vital to safety and comfort on a cave trip -- you don't want the other party members to get cold and stiff waiting for you to feed rope through the rack for the whole rappel. Try a new rappel device, such as rappel racks made of different materials or configurations, bobbins, and carabiner/brake

bar sets. Each of these devices has a different set of quirks and you might be called upon to use one in an emergency.

Practice switching from rappel to ascend. This is a pretty easy maneuver, but it requires a fairly careful adjustment of the sling length on your safety Jumar. It is also the most commonly needed advanced technique, since it might be needed anytime by the first person to descend into a pit on a given rope.

Practice taking your harness on and off quickly. This is useful on a cave trip to avoid slowing down the group when the time comes to leave.

Learn how to self-start easily and quickly. Self-starting is always needed by the last climber and is often needed if the climbing zone is dangerous to a bottom belayer, due to debris at the lip. Foot Gibbs rigs are especially prone to difficult self starts.

Learn how to climb efficiently. Keep your chest harness as tight as you can stand it. This keeps you vertical when climbing. You lose efficiency very quickly when you start tipping backwards. Learn to climb with your pack tethered to your seat harness instead of your back. Adjust your ascender position to slide up smoothly and grab the rope on the first downward movement. Avoid swinging your arms and legs, use your energy for straight upward motions.

Learn to use a new climbing system. Practice more advanced maneuvers, such as crossing a knot. This is fairly easy on ascent, but can be difficult on descent. You need to figure out how to release your safety ascender once the rack is rigged below the knot. A similar problem is encountered when switching from ascent to rappel. Try it low to the ground first, so you can escape easily if it doesn't work on the first try. Learn how to cross a reelay in both directions.

In practice sessions, one could learn advanced vertical techniques, most often used in rescues. For instance, lowering and hauling a disabled caver, rigging and using a tyrolean traverse safely, or setting an expansion bolt. While rescues are needed infrequently, the availability of these skills in a caving party can often eliminate the need for a rescue when a problem arises.

Above all, have fun, but keep safety in mind at all times. Plan for possible problems before attaching yourself to the rope. Watch your companions. Don't be afraid to stop someone who appears to be doing something dangerous -- they may have forgotten something or had an unnoticed equipment problem. Shout ROCK! when you drop something over the lip.

And don't step on the rope!

Reprinted from the D.C. Speleograph - Aug. 94

How-to Books Worth Reading

By Bill Mixon, NSS #5728 (Austin, TX)

Vertical. Alan Warild.

Comprehensive guide that describes all climbing systems equally well and fairly. Rigging section emphasizes European style. Warild is fond of solo trips to the bottom of 1000-meter-deep caves, doing all the rigging himself, so his ultra-lightweight "cord technique" is included. I think this is the best book on vertical techniques available.

On Rope II. Bruce Smith and Allen Padgett.

The American vertical caver's bible. Particularly good on the ropewalker system of climbing. Frog system thoroughly discussed in substantial detail. Rigging sections moves to a more complete discussion of a modern technical approach. Includes some fairly esoteric subjects like very long rappels and highlines. A new chapter includes rope use by Arborists, Water Rescuers and other Industrial Users.

Single Rope Techniques. A guide for vertical cavers. Neil R. Montgomery.

The first real vertical caving how-to book, and probably had much to do with the popularity of the term SRT. But now getting rather long in the tooth. For instance, the frog system is described using Jumars as the ascenders. Looking through it, though, I'm surprised to see how little things have really changed in twenty years.

Vertical Caving. Mike Meredith and Dan Martinez.

This small British book teaches the European system of rigging and climbing almost exclusively, but it does a pretty good job of that for its small size. The original edition (undated) by Meredith alone was translated into a number of languages, including at least German and Croatian.

Single Rope Technique. A training manual. Dave Elliot.

Another little British book giving the basics of European-style vertical caving.

Reminders For Safe Caving

By Miriam Cuddington, NSS #13078 (Moulton, AL)

We all should know that in order to do any sport safely, we should use "common sense". Sometimes we get so excited about our enjoyment of the sport, we seemingly forget some basic guidelines concerning safety.

I know the below reminders are few, but maybe it will help us to think of more ways to be safe, depending on one's situation. Some reminders are:

1. Take proper care of your equipment. Make a habit of checking all parts for wear and tear. Replace or repair as needed. Keep it as clean as possible. Try to make a habit of cleaning it after each trip so it will be ready for the next trip. It may also be a good idea to pack it in a bag of your choice in case of emergency and/or a friend calls you unexpectedly and invites you on a trip.
2. Keep your ropes clean. Aluminum may not come off, but most grit can be washed off with a rope washer or whatever "tools" you find useful. Of course, avoid sharp objects, edges, etc., with whatever you use to wash the rope. Try to avoid strong detergents and fabric conditioners.
3. Ropes should be padded as well as possible. The width of the pad should allow for any movement side to side that may occur during use. Length of pad depends on the "drop conditions" and length. We have pads of different lengths, so we can choose what we need for the drop. Also, we have a shorter rope, just to tie the pads on. This is helpful in some situations and clears the main line for full usage. It is tied securely, in case someone may need to attach to it.
4. Speaking of attachments, I feel it's a good idea to carry a quick attachment safety (QAS) on you. It should be in addition to your climbing system. It should be readily available at any time. Murphy's Law never takes a vacation!
5. Be very familiar with your climbing and rappelling device. Try to choose a "rope friendly" rappel device. Be sure you can control your descent without having to use a lot of energy. Be sure you have control close to the ground. You will need energy to do the cave, climb out and get back to your vehicle or camp, etc. Also, if an emergency arises, you can be an asset. Being in good physical condition can always be of help.
6. Check before you leave home to make sure that your destination is accessible. When you arrive, be sure to park your vehicle where the

landowner(s) wish. Be an environmental conscious person as well as a properly behaved person. Don't assume that no one else is around.

7. Take appropriate caving gear, lights, food, water, clothing and foot wear, according to your destination.. Don't assume that someone will provide them for you.
8. I strongly suggest one should avoid alcoholic beverages while caving. They could dehydrate you and affect your reaction time and "judgment" which in turn, affect your safety and the safety of others. There are many other places away from the ropes and trips where one can "partake" more safely.
9. Sometimes I won't go caving with a person or persons because I feel they aren't safe and /or would make the trip unpleasant for other reasons. Each person has to decide on this matter themselves.

Check the weather forecast as thoroughly as possible. Some places are deadly, for whatever reason. I'd abort a trip rather than chance that someone could get hurt or killed. There are a million other things one could think of to help cave safely. Take care out there.

Minutes of the 1996 NSS Vertical Section Meeting

August 5, 1996

The 1996 NSS Vertical Section meeting and papers session was held Monday, August 5, 1996 at the Salida High School in Salida, Colorado. Executive Committee (EC) members present were Chairman Bruce Smith, Contest Coordinator Bill Cuddington, Vertical Techniques Workshop Coordinator David McClurg, Training Coordinator Gary Bush, Secretary/Treasurer Gary Taylor, Bill Boehle, and Miriam Cuddington. Approximately 70 Vertical Section members were in attendance.

Chairman Bruce Smith called the meeting to order at 9:10 AM.

Symbolic Devices Chair Report: Tray Murphy reported we had a total of five mail order sales this year. With the printing of new issues of Nylon Highway we hope to see more sales. He is looking for a bandanna supplier. Many members are interested in a nice porcelain coffee mug. We'll try to have by the next year.

Secretary's Report: Gary Taylor announced we have approximately 2100 members and former members in the database. Out of that, 621 were members before 1994. A total of 359 did not renew their membership after 1994. A total of 373 are paid through 1995; 325 through 1996; 157 through 1997; 111 through 1998; and 60 through 1999. A total of 26 are paid through 2000 and beyond, up to 2011.

Gary summarized the minutes of last year noting that On Rope had generated \$230,000 for the NSS as of summer of 1995. Motions were read and seconded for creation of Education Chair and for 2 year terms for Executive Committee members. Defeated was a motion for rental of the Contest clock. The minutes were approved as published.

Treasurer's Report: As of July 1, 1995 the GMAC "high interest earning" account had a balance of \$7945.11 . In regular Checking account there was \$2883.71, for a total of \$10,828.82. Since then we made 373.97 in interest. There were withdrawals from the GMAC account of \$2200 for the Jeff Power Nylon Highway, and \$2000 to our regular checking account. Nylon Highways 39 and 40 cost \$2652 and \$1131 to print respectively, with an additional \$84.28 in setup fees. Postage for the two issues will be included in next year's expenses. There were an additional small amount for sending items back and forth between the Editor and Secretary/Treasurer. Also there was a membership approved \$614.11 reimbursement to Allen Padgett and Bruce Smith for On Rope II cost overruns.

As of August 1, 1996 the GMAC account contained \$4119.08. Our Regular Checking account had \$3385.47. Thus, total cash on hand is \$7504.55.

The Treasurer's Report was approved as read.

Editor's Report: Bruce Smith thanked Wm Shrewsbury for working to get Nylon Highway back in print. He spearheaded getting Maureen Handler to finish Nylon Highway 39, and Geary Schindel to publish Nylon Highway 40. He was responsible for both printing and the mailing of the issues. He received a round of applause from the members.

Bruce explained that former editor Gary Power has disappeared with \$2200. We have tried in vain to contact him. His last known address was Ellensburg, Washington. Any suggestions on how to locate him would be appreciated.

Contest Chair Report: Bill Cuddington thanked the Colorado Grotto for the gym and facilities. There is no smoking anywhere on the school grounds. He thanked Bill Boehle for helping him set up the contest. He gave several guidelines for competing in and running the contest. He thanked PMI for two 500 foot pieces of rope. The group discussed the new Vertical Medley, in which four people climb 30 meters, each using a separate system, for a total of 120 meters. Contestants must be members of the same grotto to compete.

Miriam Cuddington noted the Vertical contest is starting later in the week due to the altitude. Awards will be presented Friday at 1PM in the auditorium along with the Speleo Olympics and Survey Contest.

Vertical Techniques Workshop Report: Dave McClurg thanked the 1996 Convention staff for their cooperation in facilitating facilities. Again, we are full, but we still need more instructors.

Rebelay Workshop Report: Gary Bush reported that the Rebelay Workshop will start at 2PM Tuesday in the bleacher area at the football stadium. We'll be using 9mm rope as the Europeans do. This will be good practice for those attending the International Congress next year.

Basic Vertical Training Course Outline: Gary Bush presented the Basic Vertical Training Course Outline to membership. It will be sold for \$20 for the basic set of five 52 page instructor manuals which covers the basic course, a forms set for copying including a class schedule with suggested times for each, student forms, waiver of liability, written checklist, a written exam for which 70 is the minimum score, and a certificate of completion. Additional instructor manuals are \$3. This gives each grotto a standard Vertical Section approved course for basic single rope techniques instruction. Gary added that this course is available at this convention for a one time special of \$15.

Gary asked the membership for permission to print an additional 32 page student manual so instructors wouldn't have to copy to give to students. An additional \$15 would provide 12 Student sets consisting of a student manual, exam form, and other materials. Gary proposed spending \$900 for 1500 student sets. This would cost the Section 68 cents a set, and sell for \$1.50 per set. Bruce noted that the Executive Committee approved this at their meeting Sunday night.

It was moved and seconded that: *The Section spend \$900 for 1500 student sets.*

The motion was approved unanimously. These will be distributed by Gary, and should be available within a month after convention.

On Rope II Update: Bruce reported that the book had been written, and the illustrations completed. They have been turned over to the layout committee. Barb Ritts proofread the book and was able to do some fine tuning of the final galley proofs. David McClurg, as chair of the NSS Special Publications Committee, noted that it is good for a book to sell 10,000 copies. On Rope has sold 40,000 plus. The book is expected out in October and will sell for \$35. There are 650 illustrations by Ron Buffington. For computer types, the old book had 750,000 bytes of information, the new one has 1.5 million.

Old Business

Education and Training Director: There was a second and final reading of the motion:

The Vertical Section will have an appointed position of Education and Training Director.
The position is currently being done by Gary Bush. The motion was approved unanimously.

Two Year Terms for Executive Committee Members: There was a second and final reading of the motion:

Elected Executive Committee members of the Section will have two year terms of office. Half of these elected positions will be up for re-election each year.

After discussion the motion passed unanimously.

Appointed Editor and Secretary Treasurer: There was a second and final reading of the motion:

In the event of a nonperformance by either an Editor or Secretary/Treasurer, the Executive Committee shall have the latitude to dismiss either person from their position and appoint a replacement to fill the term.

In discussion it was noted the actual motion from last year was that the two offices be appointed. It would be a second motion to give the Executive Committee the power to replace or fire someone in a position.

Gary Bush amended: *The Executive Committee of the Vertical Section shall have the authority to appoint the Editor and Secretary/Treasurer.*

The amendment passed.

In discussion on the amended motion, it was observed that four EC members would be elected and five would be appointed. There was some concern about this. It was revealed that the Vertical Contest and Vertical Techniques Workshop Chair were made appointed members of the Executive Committee to provide for continuity and to recognize the work they are doing. These two positions should have voice in Section matters.

In voting, there were 28 yes votes and 16 no votes. The motion failed by one vote.

Gary Storrick moved: *The Vertical Section reconsider the original motion prior to the amendment.* The move to reconsider passed unanimously.

The reconsidered motion:

In the event of a nonperformance by either an Editor or Secretary/Treasurer, the Executive Committee shall have the latitude to dismiss either person from their position and appoint a replacement to fill the term.

In voting, this passed with only one vote against.

The fourth motion from last year was withdrawn.

New Business

Dale Lofland moved: *The Vertical Section increase the student charge of the Vertical Techniques Workshop from \$15 to \$25 in 1997.*

In discussion, it was disclosed that each year the contest turns people away. We have 30+ volunteers who work enthusiastically for 1/2 day each year. That is a lot of hours. The Section could use the compensation. One suggested that we decrease the cost of the course so more could take it. This was considered not feasible due to lack of facilities, time, and people. One member noted that people taking the course always ask the instructors why aren't we charging more.

In voting, the motion passed unanimously.

In elections, Gary Taylor was reelected Secretary/Treasurer. Wm Shrewsbury was elected Editor. In Executive Committee elections By virtue of being the two top vote getters, Bruce Smith and Bill Bussey will serve two year terms, while Miriam Cuddington and Tray Murphy will serve one year terms.

Respectfully Submitted,
Bill Bussey, for Gary Taylor

Advertisements

Please patronize the vendors who support the *Nylon Highway*.

ON ROPE 1,
For the Serious Rope

Climbing Systems:
WORLD'S LARGEST MANUFACTURER

- COMFORT
- QUALITY
- VARIETY

S.S. Racks:
Finest selection

Free Catalog!

www.onrope1.com

6313 Jan Lane Dr. Harrison, TN
423-344-4716



Copyright © 2000 Vertical Section of the NSS, Inc. - All Rights Reserved.